

# Aerobee Upper Interstage

John Coker

(650) 685-1890

all parts made of 1/8" stock

stage tubes are 1/8" I.D. and 2" long

motor tube is 2.125" I.D. and 3" long

skirt is 3.0" O.D. and 1" long

retaining screw holes with 10-32 thread

liftoff detect is a plain hole (0.225")

stage tubes must mate with struts on lower interstage

bottom view (holes)

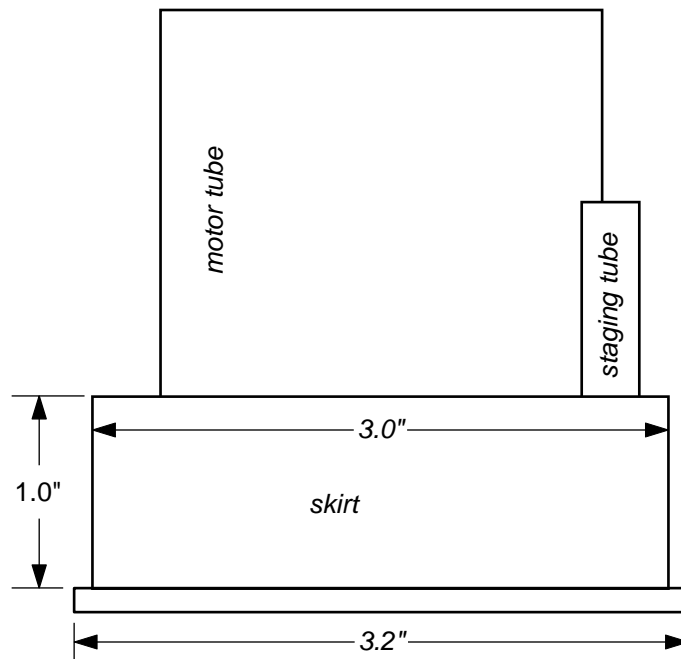
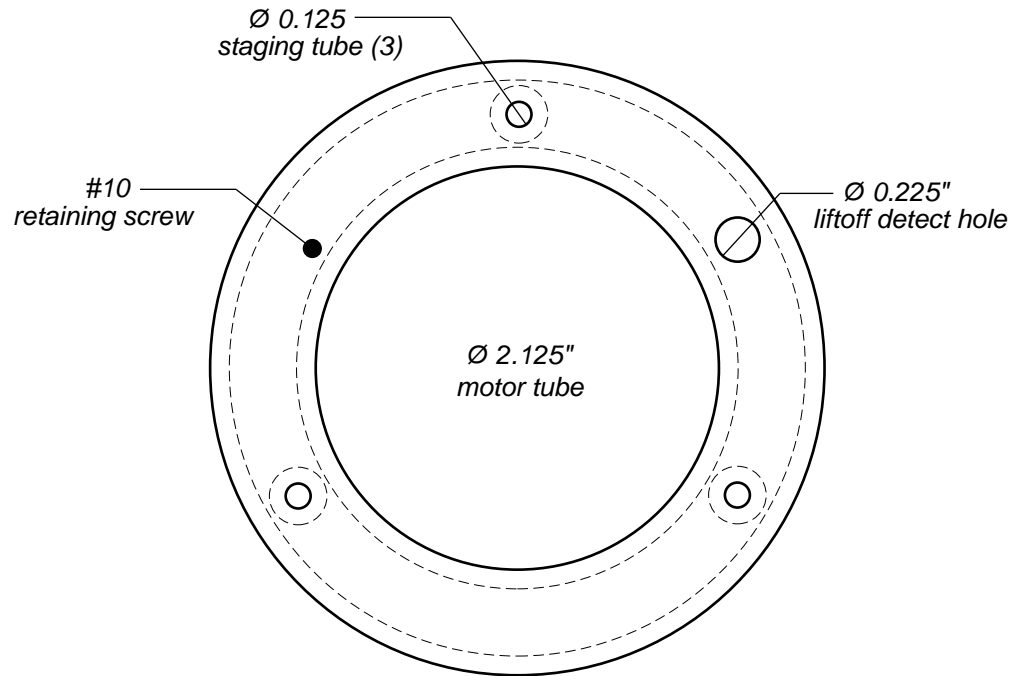

side view (tubes)